



Item # \_\_\_\_\_

C.S.I. Section 11420

# WLG400

## FREE STANDING ECONOMY GAS FRYER



### SPECIFICATIONS:

45 - 50 lb. capacity free standing model gas fryer, Wolf Model No. WLG400. Stainless steel front top and door. Set of 4 adjustable nickel plated steel legs. Stainless steel fry tank with three heat exchanger tubes and a "V" shaped cold zone. 1 1/4" full port ball type drain valve. Twin fry baskets with plastic coated handles. 120,000 BTU/hr. input. Behind the door millivolt thermostat control adjusts from 200° to 400°F.

Overall dimensions: 15 1/2"w x 30 1/4"d x 36 1/4"h.

CSA design certified. NSF listed.

### SPECIFY TYPE OF GAS WHEN ORDERING.

- Natural Gas
- Propane Gas

### SPECIFY ALTITUDE:

- Natural Gas for above 2000 ft
- Propane Gas for above 3500 ft.

### STANDARD FEATURES

- Stainless steel fry tank, 45 - 50 lb. capacity.
- Large cold zone area.
- 1 1/4" full port ball type drain valve.
- Stainless steel front and door.
- G90 high grade galvanized non corrosive finish sides and back.
- Door liner for added stability.
- Set of four nickel plated legs adjustable to 7".
- Twin fry baskets with plastic coated handles.
- 120,000 BTU/hr. input.
- Behind the door snap action millivolt thermostat control adjusts from 200° to 400°F with standing pilot.
- Millivolt System - Requires no electric hook-up.
- Hi-limit shut-off protector shuts off gas combination valve and standing pilot.
- Built in flue deflector.
- Nickel plated tube rack.
- Earth magnet to secure closed door.
- Easily removable stainless steel basket hanger for cleaning.
- Vulcan-Hart (Vulcan) warrants the LG400 Gas Fryer to be free of defects in materials and workmanship for a period of 1 year from the date of original installation.
- Stainless steel fry tank will be warranted for 1 year. If tank is found to have a leak and is verified by an authorized service agency, the entire LG400 fryer will be replaced. Replacement fryer will be warranted for the balance of the original warranty.

### ACCESSORIES

- Casters 6" adjustable to 7", 2 locking, 2 non-locking
- Stainless steel tank cover.
- Grease protector strips.
- Single large basket - 13"w x 13 1/4"d x 5 1/2"h.
- Set of twin baskets - 6 1/2"w x 13 1/4"d x 6"h.
- Set of tri baskets - 4 1/4"w x 13 1/4"d x 5 1/2"h
- FRYMATE - VX15 add-on Frymate™ Dump Station.
- Flexible gas hose with quick disconnect.



# WLG400

## FREE STANDING GAS FRYER

### IMPORTANT

1. A combination valve with pressure regulator is provided with this unit.  
Natural Gas 4.0" (102 mm) W.C.  
Propane Gas 10.0" (279 mm) W.C.
2. An adequate ventilation system is required for Commercial Cooking Equipment. Information may be obtained by writing to the National Fire Protection Association, Batterymarch Park, Quincy, MA 02269. When writing refer to NFPA No. 96.
3. All models require a 6" (152 mm) clearance at both sides and rear adjacent to combustible construction.
4. All models require a 16" (407 mm) minimum clearance to adjacent open top burner units.
5. This appliance is manufactured for commercial installation only and is not intended for home use.

### SERVICE CONNECTIONS:

- (P1) 1/2" (13 mm) rear gas connection (single units).

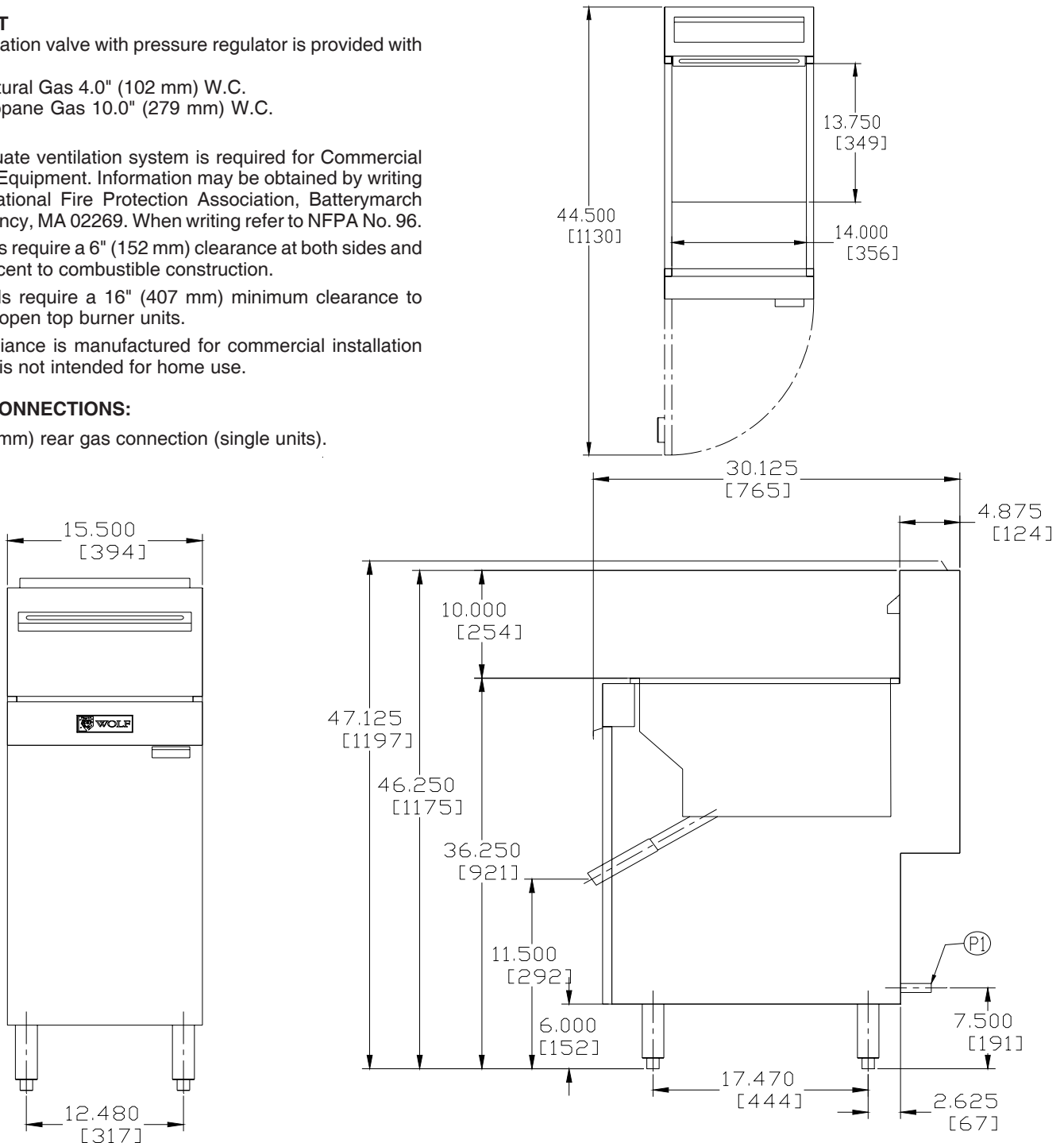

MODEL	WIDTH	DEPTH	OVERALL HEIGHT	WORKING HEIGHT	TANK SIZE	BTU/HR.	FRY COMP. CAPACITY	APPROX. SHP.WT.
WLG400	15 1/2"	30 1/4"	47 1/8"	36 1/4"	14" x 14"	120,000	45 - 50 lbs.	210 lbs./91 kg

**NOTE:** In line with its policy to continually improve its products, Wolf Range Company reserves the right to change materials and specifications without notice.

WOLF RANGE COMPANY, P.O. BOX 696, LOUISVILLE, KY 40201, TEL. 1-800-814-2028