



# CHALLENGER XL™ SERIES

## 72" GAS RESTAURANT RANGE

### BURNER / FRY TOPS



Model C72SS-8FT24 shown with optional casters

#### SPECIFICATIONS

72" wide gas restaurant range, Wolf Model No. C72SS-8FT24. Fully MIG welded aluminized steel frame for added durability. Stainless steel front, sides, backriser, highshelf and 6" adjustable legs. Extra deep crumb tray with welded corners. Eight 30,000 BTU/hr cast burners with lift-off burner heads. Energy saving flashtube open burner ignition system (one pilot for every two burners) shrouded for reliability. 7/8" thick x 24" wide manual fry top, 40,000 BTU/hr. Heavy duty cast grates, easy lift-off 12" x 12 1/2" in the front and 12" x 14 1/2" in the back to better accommodate stock pots or large pans. Grates have a built in aeration bowl for greater efficiency. Burner knobs are cool to the touch, high temperature material. Two ovens: 35,000 BTU/hr standard bakers depth ovens with porcelain oven bottom and door panel, measures 26 1/2"d x 26 3/8"w x 14"h. Oven thermostat adjusts from 250°F to 500°F with a low setting. Each oven is supplied with two racks, two rack guide sets, and four rack positions. Oven doors are heavy duty with an integrated door hinge/spring mechanism requiring no adjustment. 1" rear gas connection and pressure regulator. Total input 350,000 BTU/hr.

#### Exterior Dimensions:

34 3/4"d x 72"w x 58"h on 6" adjustable legs

- |                                       |                                       |                                       |
|---------------------------------------|---------------------------------------|---------------------------------------|
| <input type="checkbox"/> C72SS-10FT12 | <input type="checkbox"/> C72CC-10FT12 | <input type="checkbox"/> C72SC-10FT12 |
| <input type="checkbox"/> C72SB-10FT12 | <input type="checkbox"/> C72CB-10FT12 | <input type="checkbox"/> C72SS-8FT24  |
| <input type="checkbox"/> C72CC-8FT24  | <input type="checkbox"/> C72SC-8FT24  | <input type="checkbox"/> C72SB-8FT24  |
| <input type="checkbox"/> C72CB-8FT24  | <input type="checkbox"/> C72SS-6FT36  | <input type="checkbox"/> C72CC-6FT36  |
| <input type="checkbox"/> C72SC-6FT36  | <input type="checkbox"/> C72SB-6FT36  | <input type="checkbox"/> C72CB-6FT36  |

#### STANDARD FEATURES

- Fully MIG welded frame
- Stainless steel front, sides, backriser, lift-off high shelf
- 6" Stainless steel adjustable legs
- 30,000 BTU/hr open top burners with lift-off heads
- 7/8" thick manual fry top. 4" wide front grease trough
- Shrouded flash tube pilot system (one pilot per two burners)
- Heavy duty cast grates, easy lift-off 12" x 12 1/2" in front and 12" x 14 1/2" in the rear
- Extra deep pull out crumb tray with welded corners
- 35,000 BTU/hr baker's depth standard oven cavity measures 26 1/2"d x 26 3/8"w x 14"h
- Oven thermostat adjusts from 250°F to 500°F
- Two oven racks and four rack positions for each oven
- 35,000 BTU/hr Snorkler convection oven in place of std. oven 26"d x 26 1/8"w x 13 7/8"h (115v - 1 phase blower motor 4 amp, 6' cord and plug), includes three oven racks
- One year limited parts and labor warranty

#### OPTIONAL FEATURES (Factory Installed)

- 6" stainless steel stub back
- Reinforced high shelf for mounting salamander broiler
- Hot top section in lieu of one open burner
- Thermostatically controlled (snap-action) on 24" and 36" only

#### ACCESSORIES (Packaged & Sold Separately)

- Extra oven rack
- Extra rack guides (set of two)
- Casters (set of six)
- Flanged feet (set of six)
- Reinforced high shelf for mounting salamander broiler

***This appliance is manufactured for commercial use only and is not intended for home use.***



# WOLF RANGE COMPANY

Vulcan & Wolf Range

a division of ITW Food Equipment Group LLC

P.O. Box 696 ■ Louisville, KY 40201 ■ Toll-free: 1-800-814-2028 ■ Local: 502-778-2791 ■ Quote & Order Fax: 1-800-444-0602



# CHALLENGER XL™ SERIES

## 72" GAS RESTAURANT RANGE

### BURNER / FRY TOPS

#### INSTALLATION INSTRUCTIONS

1. A pressure regulator sized for this unit is included.  
Natural gas 5.0" W.C., propane gas 10.0" W.C.
2. Gas line connecting to range must be 1" or larger. If flexible connectors are used, the inside diameter must be 1" or larger.
3. An adequate ventilation system is required for commercial cooking equipment. Information may be obtained by writing to the National Fire Protection Association, 1 Batterymarch Park, Quincy, MA 02269, www.NFPA.org. When writing, refer to NFPA No. 96.
4. These units are manufactured for installation in accordance with ANSZ223.1A (latest edition), National Fuel Gas Code. Copies may be obtained from The American Gas Association, 400 N Capitol St. NW, Washington, DC 20001, www.AGA.org.

5. Clearances

	<u>Rear</u>	<u>Sides</u>
Combustible	6"	10"
Standard Oven Non-combustible	0"	0"
Convection Oven Non-combustible	Min. 4"	0"
6. For proper combustion, install equipment on adjustable legs or casters provided with unit.
7. For proper combustion, install equipment on adjustable legs or casters provided with unit.

**NOTE:** In line with its policy to continually improve its product, Wolf Range Company reserves the right to change materials and specifications without notice.

Specify type of gas when ordering. Specify altitude when above 2,000 feet.

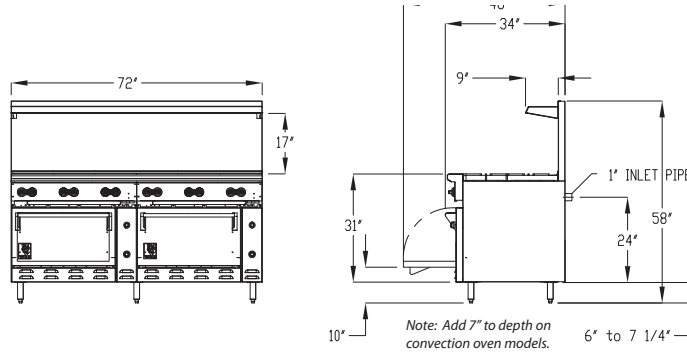

TOP CONFIGURATION	MODEL NUMBER	DESCRIPTION	TOTAL INPUT BTU / HR	SHIPPING WEIGHT LBS / KG
	C72SS-10FT12	10 Burners / 12" Fry Top / 2 Standard Ovens	390,000	1040 / 472
	C72CC-10FT12	10 Burners / 12" Fry Top / 2 Convection Ovens	390,000	1160 / 526
	C72SC-10FT12	10 Burners / 12" Fry Top / Standard Oven / Convection Oven	390,000	1100 / 499
	C72SB-10FT12	10 Burners / 12" Fry Top / Standard Oven / Storage Base	355,000	1010 / 458
	C72CB-10FT12	10 Burners / 12" Fry Top / Convection Oven / Storage Base	355,000	1070 / 485
	C72SS-8FT24	8 Burners / 24" Fry Top / 2 Standard Ovens	350,000	1050 / 476
	C72CC-8FT24	8 Burners / 24" Fry Top / 2 Convection Ovens	350,000	1170 / 531
	C72SCS-8FT24	8 Burners / 24" Fry Top / Standard Oven / Convection Oven	350,000	1110 / 503
	C72SSB-8FT24	8 Burners / 24" Fry Top / Standard Oven / Storage Base	315,000	1020 / 463
	C72SCB-8FT24	8 Burners / 24" Fry Top / Convection Oven / Storage Base	315,000	1080 / 490
	C72SS-6FT36	6 Burners / 36" Fry Top / 2 Standard Ovens	310,000	1090 / 494
	C72CC-6FT36	6 Burners / 36" Fry Top / 2 Convection Ovens	310,000	1210 / 549
	C72SC-6FT36	6 Burners / 36" Fry Top / Standard Oven / Convection Oven	310,000	1150 / 522
	C72SB-6FT36	6 Burners / 36" Fry Top / Standard Oven / Storage Base	275,000	1060 / 481
	C72CB-6FT36	6 Burners / 36" Fry Top / Convection Oven / Storage Base	275,000	1120 / 508

# WOLF RANGE COMPANY

**Vulcan & Wolf Range**  
a division of ITW Food Equipment Group LLC

P.O. Box 696 ■ Louisville, KY 40201 ■ Toll-free: 1-800-814-2028 ■ Local: 502-778-2791 ■ Quote & Order Fax: 1-800-444-0602