



RB36 GAS SALAMANDER BROILER



Model RB36



SPECIFICATIONS

Gas salamander broiler, Wolf Model No. RB36. Six 11,000 BTU/hr. bar-type burners with stainless steel radiants; 66,000 BTU/hr. total input. Infinite heat control valve. Pilot ignition system. Chrome plated trigger grip control handle provides positive positioning of the broiling carriage. Heavy-duty chrome plated broiling grid measures 27½" w x 13" d. Removable full width spillage pan. ¾" top gas connection and gas pressure regulator.

Exterior Dimensions:

36" w x 19" d x 17½" h.

CSA design certified. NSF listed.

**SPECIFY TYPE OF GAS WHEN ORDERING.
SPECIFY ALTITUDE WHEN ABOVE 2,000 FT.**

RB36 Gas Salamander Broiler

STANDARD FEATURES

- Stainless steel front, top and sides.
- Six 11,000 BTU/hr. bar-type burners with stainless steel radiants; 66,000 BTU/hr. total input.
- Infinite heat control valve.
- Standing pilot ignition system.
- Chrome plated trigger grip control handle provides positive positioning of the broiling carriage. Heavy-duty chrome plated broiling grid measures 27½" w x 13" d.
- Removable full width spillage pan.
- ¾" top gas connection and gas pressure regulator.
- Can be range mounted (with a reinforced backriser), wall mounted (with optional wall mount brackets) or counter mounted (with optional leg set).
- One year limited parts and labor warranty.

OPTIONAL FEATURES

- Set of chrome wall mount brackets.
- Set of four 4" legs with adjustable feet.



a division of ITW Food Equipment Group LLC

RB36 GAS SALAMANDER BROILER

INSTALLATION INSTRUCTIONS

1. A gas pressure regulator supplied with the unit must be installed.
Natural Gas 5.0" (127 mm) W.C. Propane Gas 10.0" (254 mm) W.C.
2. An adequate ventilation system is required for commercial cooking equipment. Information may be obtained by writing to the National Fire Protection Association, 1 Batterymarch Park, Quincy, MA 02169, www.NFPA.org. When writing refer to NFPA No. 96.
3. These units are manufactured for installation in accordance with National Fuel Gas Code, ANSI-Z223.1/NFPA #54 (latest edition). Copies may be obtained from The American Gas Association, Accredited Standards Committee Z223 @ 400 N. Capital St. NW, Washington, DC 20001, or the Secretary Standards Council, NFPA, 1 Batterymarch Park, Quincy, MA 02169-7471.

NOTE: In the Commonwealth of Massachusetts

All gas appliances vented through a ventilation hood or exhaust system equipped with a damper or with a power means of exhaust shall comply with 248 CMR.

- | | | |
|----------------|-------------|-----------------|
| 4. Clearances: | Combustible | Non-Combustible |
| Rear | 0" | 0" |
| Sides | 6" | 0" |
| Bottom | 10" | 4" |
5. This appliance is manufactured for commercial installation only and is not intended for home use.

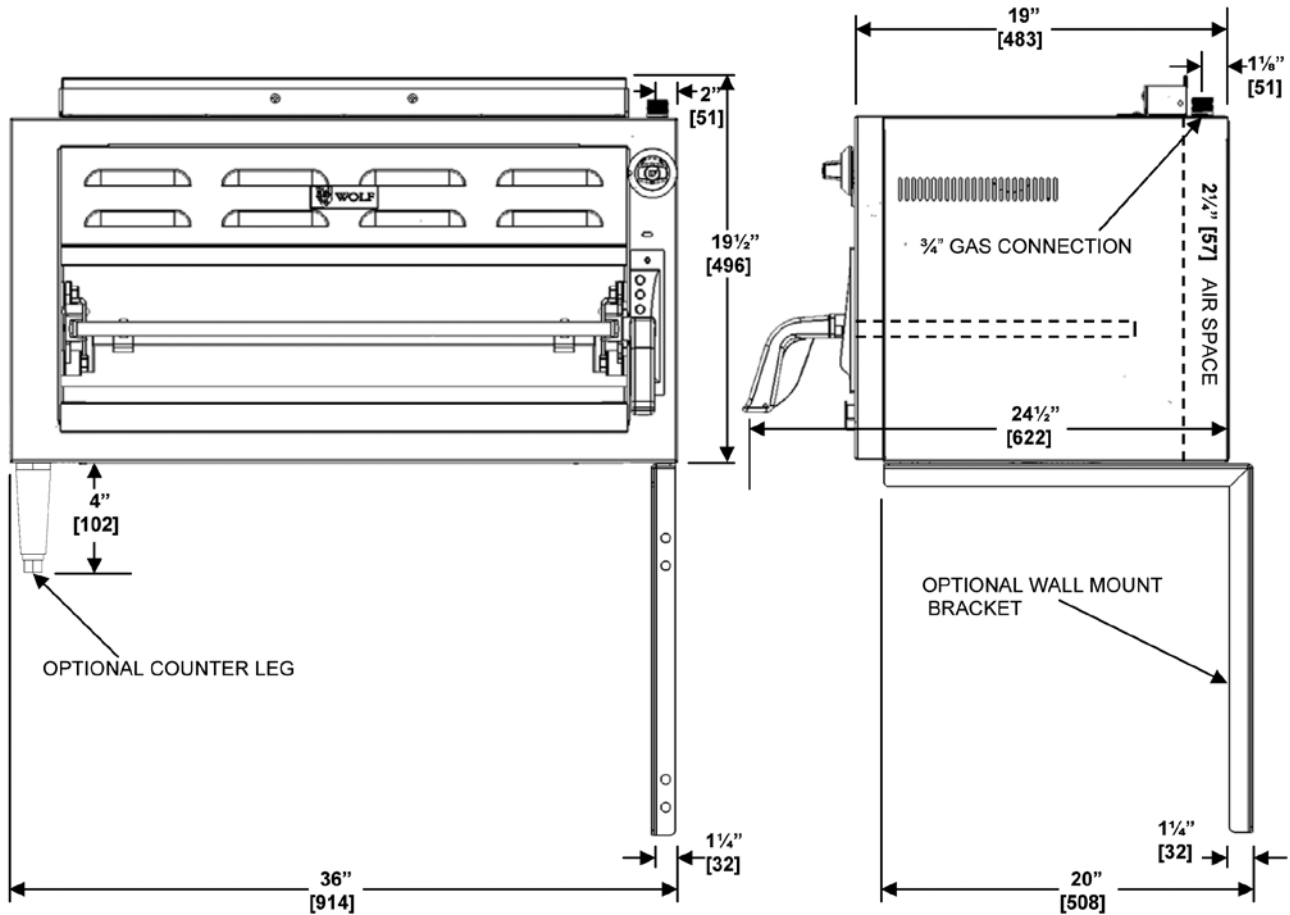

MODEL	WIDTH	DEPTH	HEIGHT	GRID RACK W X D	NO. OF BURNERS	TOTAL BTU/HR.	APPROX. SHIP. WT.	COUNTER LEG SET ACCESSORY CODE	WALL MOUNT BRACKET SET ACCESSORY CODE
RB36	36" (914 mm)	19" (483 mm)	17 1/2" (445 mm)	27 1/2" x 13" (699 mm x 330 mm)	6	66,000	180 lbs. (81 kg)	COUNTER-ADJLEG	WALLMNT-CHRBKR