



# THERM-O-RAY SERIES INFRARED GAS GRIDDLES

**WOLF RANGE COMPANY**

**MODEL: THERM-O-RAY SERIES Infrared Gas Griddles**



**Model IRG-36**

**BASIC MODELS:**

- IRG-36**     36" wide, 60,000 BTU/hr.
- IRG-48**     48" wide, 80,000 BTU/hr.
- IRG-60**     60" wide, 100,000 BTU/hr.
- IRG-72**     72" wide, 120,000 BTU/hr.

**KEY FEATURES:**

- Stainless steel front and sides.
- 4" adjustable chrome plated legs.
- 1" thick, 24" deep highly polished steel griddle plate.
- 4½" high stainless steel side and back splashes.
- 3" wide stainless steel front grease trough drains into large capacity grease collector(s). (60" and 72" griddles have two grease collectors.)
- Full width chrome plated guard rail.
- One 20,000 BTU/hr. infrared burner with solid state temperature control and electronic spark igniter for each 12" of griddle width. Controls are recessed and concealed behind a hinged panel. Adjusts from 150° to 500°F.
- ¾" rear gas connection and gas pressure regulator.
- 115 volt, 50/60 Hz, 1 phase control circuit. ½ amp draw. 6' power cord with 3 prong plug.
- One year limited parts and labor warranty.

**OPTIONAL FEATURES:**

- Chrome griddle plate.
- Side grease collector(s). Drip edge and one grease collector on the left side. Adds 3" to overall width. Grease collectors on both sides. Adds 6" to the overall width.
- Floor model griddle with chrome legs and stainless steel undershelf.
- Set of four casters (two locking).

**DESCRIPTION:**

Gas infrared griddle, Wolf Model No. \_\_\_\_\_. Stainless steel front and sides. 4" adjustable chrome plated legs. 1" thick, 24" deep highly polished steel griddle plate. 4½" high stainless steel side and back splashes. 3" wide stainless steel front grease trough drains into large capacity grease collector(s). Full width chrome plated guard rail. One 20,000 BTU/hr. infrared burner with solid state temperature control and electronic spark igniter for each 12" of griddle width. Controls are recessed and concealed behind a hinged panel. Adjusts from 150° to 500°F. ¾" rear gas connection and gas pressure regulator. 115 volt, 50/60 Hz, 1 phase control circuit. ½ amp draw. 6' power cord with 3 prong plug.

Exterior dimensions: \_\_\_\_"w x 33½"d x 13¼" working height on 4" legs.



**Design Certified by the American Gas Association  
Design Certified by the Canadian Gas Association  
Listed by the National Sanitation Foundation**

Approved by \_\_\_\_\_

Date: \_\_\_\_\_

**SPECIFY TYPE OF GAS WHEN ORDERING.  
SPECIFY ALTITUDE WHEN ABOVE 2,000 FT.**

**WOLF RANGE COMPANY**

Wolf Range Company  
Division of ITW Food Equipment Group LLC  
(800) 366-9653  
www.wolfrange.com



# Therm-O-Ray Series Infrared Gas Griddles

## INSTALLATION REQUIREMENTS:

1. A gas pressure regulator sized for this unit is included. Natural Gas 5.0" W.C. Propane Gas 10.0" W.C.
2. Gas line connecting to appliance must be 3/4" diameter or larger. If flexible connectors are used, the inside diameter must be the same as the 3/4" iron pipe.
3. 115 volt, 50/60 Hz, 1 phase control circuit. 1/2 amp draw. Provided with 6' power cord with 3 prong plug.
4. An adequate ventilation system is required for commercial cooking equipment. Information may be obtained by writing to the National Fire Protection Association, 1 Batterymarch Park, Quincy, MA 02269, www.NFPA.org. When writing, refer to NFPA No. 96.
5. These units are manufactured for installation in accordance with ANSZ223.1A (latest edition), National Fuel Gas Code. Copies may be obtained from The American Gas Association, 400 N Capitol St. NW, Washington, DC 20001, www.AGA.org.
6. Clearances:
 

	Combustible	Non-Combustible
Rear	6"	0"
Sides	6"	0"

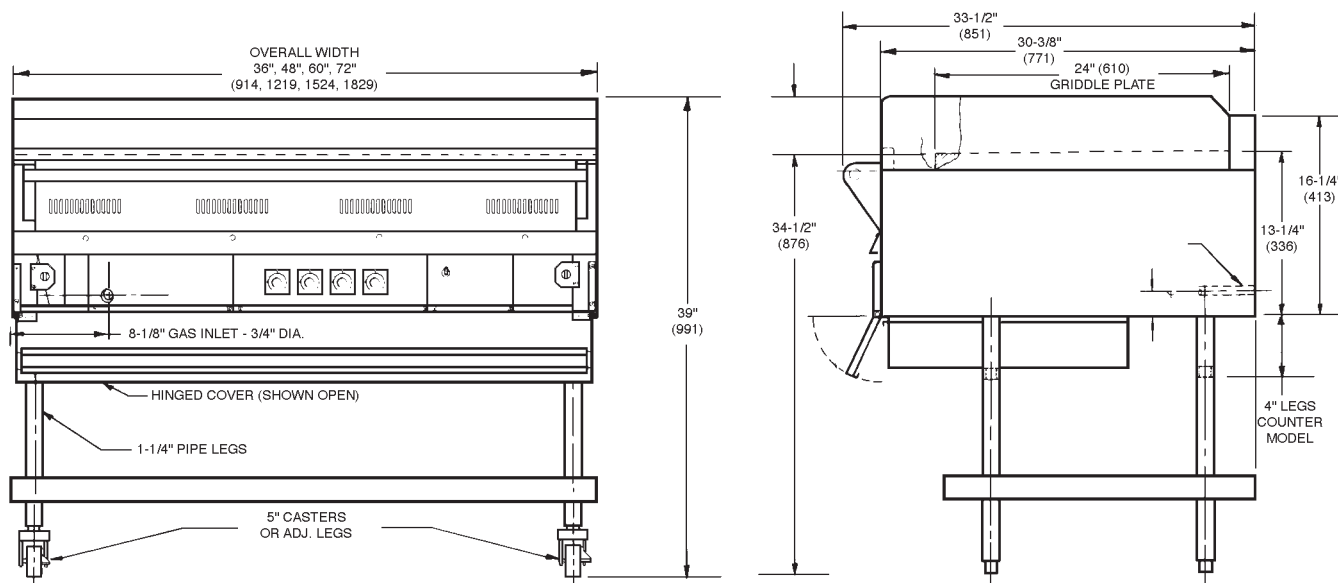

See equipment stand spec sheets for dimensions.

MODEL NO.	BTU/HR.	GRIDDLE WIDTH		GRIDDLE SURFACE DEPTH	OVERALL WIDTH	NO. OF CONTROLS	APPROX. SHIP WT. (LBS./KG)	
							COUNTER	FLOOR
IRG-36	60,000	36"	x	24"	36"	3	475/214	545/245
IRG-48	80,000	48"	x	24"	48"	4	575/259	665/299
IRG-60	100,000	60"	x	24"	60"	5	666/300	855/385
IRG-72	120,000	72"	x	24"	72"	6	855/385	1080/486

115 volt, 50/60 Hz, 1 phase control circuit. 1/2 amp draw. Provided with 6' power cord with 3 prong plug.

**NOTE:** In line with its policy to continually improve its product, Wolf Range Company reserves the right to change materials and specifications without notice.  
This appliance is manufactured for commercial use only and is not intended for home use.